

280 Coal Effect Stove

Conventional Flue

Instructions for Use, Installation and Servicing

For use in GB, IE (Great Britain and Eire)

This appliance has been certified for use in countries other than those stated. To install this appliance in these countries, it is essential to obtain the translated instructions and in some cases the appliance will require modification. Contact Dovre for further information.

IMPORTANT

Do not attempt to burn rubbish in this fire. This stove must only be operated with the door secured firmly in position. The outer casing of this stove will become hot whilst in operation, it is therefore recommended that the appliance be guarded to protect the young and infirm using a suitable guard.

Ensure that fabrics such as curtains are not positioned above or near to the stoves outer casing.

**Please read these Instructions carefully and keep them in a safe place.
They will be needed when servicing the fire.**

The commissioning sheet found on page 3 should be completed by the installer.

CONTENTS
COVERING THE FOLLOWING MODELS
DV-280CFNG
DV-280BFLPG

	PAGE
APPLIANCE COMMISSIONING CHECKLIST	3
USER INSTRUCTIONS	4
INSTALLATION INSTRUCTIONS	9
Technical Specifications	9
Site Requirements	10
Installation	11
Commissioning	15
SERVICING INSTRUCTIONS	16
Servicing Requirements	16
Fault Finding	15
How to replace parts	18
Basic spare parts list	22
Service Records	23

APPLIANCE COMMISSIONING CHECKLIST

IMPORTANT NOTICE

Explain the operation of the appliance to the end user, hand the completed instructions to them for safe keeping, as the information will be required when making any guaranteed claims.

FLUE CHECK	PASS	FAIL	
1. Flue is correct for appliance			
2. Flue flow test			
3. Spillage test			
GAS CHECK			
1. Gas soundness & let by test			
2. Standing pressure test	mb		
3. Appliance working pressure (on High Setting) NB All other gas appliances must be operating on full	mb		
4. Gas rate	m ³ /h		
5. Does ventilation meet appliance requirements			
6. Have controls been upgraded (Upgradeable models only)	8455 Standard	YES	NO
	8456 Programmable Thermostatic and Timer	YES	NO

DEALER AND INSTALLER INFORMATION

Dealer

Gas Type

.....

Installation Company

.....

Contact No.

.....

Date of Purchase

Engineer

Model No.

Contact No.

Serial No.

Corgi Reg No.

Date of Installation

This product is guaranteed for 2 years from the date of installation, as set out in the terms and conditions of sale between Dovre and your local Dovre dealer. **This guarantee will be invalid, to the extent permitted by law, if the above Appliance Commissioning Checklist is not fully completed by the installer and available for inspection by a Dovre engineer.** The guarantee will only be valid during the second year, to the extent permitted by law, if the annual service recommended in the Instructions for Use has been completed by a Corgi registered engineer, and a copy of the service visit report is available for inspection by a Dovre engineer.

USER INSTRUCTIONS

1. GENERAL

- 1.1 A competent person must carry out installation and servicing.
- 1.2 In all correspondence, please quote the appliance type and serial number, which can be found on the databadge located on a plate under the appliance.
- 1.3 Ensure that curtains are not positioned above the appliance and there is at least 300mm between the sides of the appliance and any curtains.
- 1.4 If any cracks appear in the glass panel do not use the appliance until the panel has been replaced.
- 1.5 This product is guaranteed for 2 years from the date of installation, as set out in the terms and conditions of sale between Dovre and your local Dovre dealer. Please consult with your local Dovre dealer if you have any questions. In all correspondence always quote the Model Number and Serial Number.
- 1.6 Any combustible shelves or surrounding furniture must only be fitted in accordance with the minimum dimensions detailed in diagram 1.

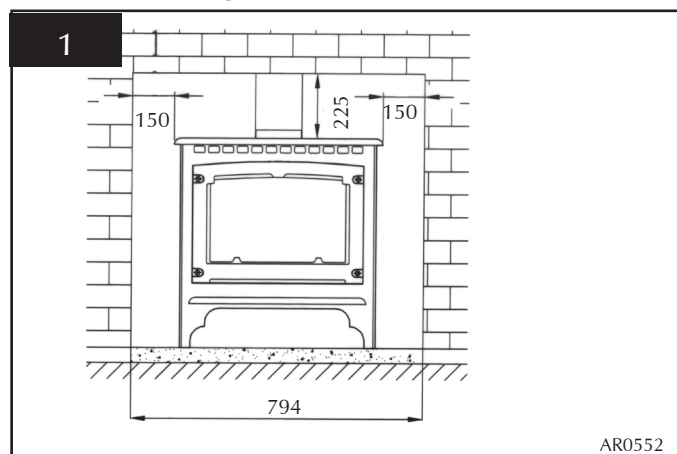

- 1.7 Contact a competent service engineer to carry out relevant spillage checks etc. following home improvements carried out after installation of this stove (e.g. the fitting of double glazing).

2. LIGHTING THE STOVE

- 2.1 The control valve is at the foot on the right-hand side of the fire. It has two controls:
 - The right-hand knob controls the pilot ignition
 - The left-hand knob controls the main burner
- 2.2 Refer to separate instructions if your fire is upgraded to include battery remote control. The instructions below apply whether or not you have the remote upgrade.

Lighting the Pilot

- 2.3 The left-hand and right-hand control knobs must both point to off (●):

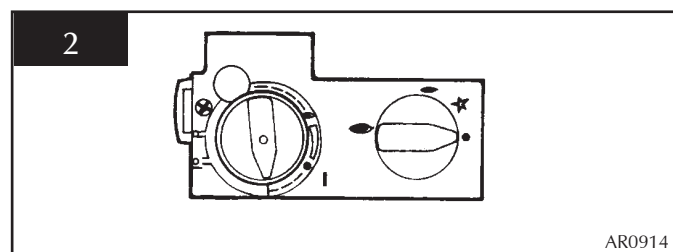

- Press in the right-hand control knob and rotate anti-clockwise until a click is heard
- Continue to press in. The knob points to the pilot (☛). The pilot is lit
- Keep the knob depressed for 10 seconds before releasing. The pilot remains lit.
- Repeat the above steps if the pilot does not stay lit

NOTE: If the pilot goes out, the Interlock system prevents you lighting again for a short period

- 2.4 If, after repeating the above steps the pilot does not light, contact your Retailer or Installer.
- 2.5 Turn the right-hand knob to the left to main burner (☞)

Adjusting the Flame height

- 2.6 You can now adjust the flame height and temperature using the left-hand control knob:
 - Turn the left-hand knob anti-clockwise to increase the flame height
 - Turn clockwise to decrease the height

YELLOW FLAMES APPEAR WHEN THE FIRE HAS REACHED SUFFICIENT HEAT – (10 TO 20 MINUTES).

IF THE FIRE IS EXTINGUISHED OR GOES OUT IN USE, WAIT 3 MINUTES BEFORE TRYING TO RELIGHT.

3. TURNING THE STOVE OFF

- 3.1 To turn the main burner out:
 - Turn the left-hand knob until it points to off (●). Just the pilot remains lit.
 - Press in and turn the right-hand knob until it points to off (●). The pilot goes out.

4. UPGRADING YOUR STOVE

- 4.1 Your stove is fitted with a control valve that can easily be upgraded to battery powered remote control. This upgrade can be fitted by anyone capable of simple DIY jobs and requires no special training. There are two versions of this control which can be obtained through your local Dovre stockist.

USER INSTRUCTIONS

- 4.2 **STANDARD REMOTE CONTROL** This remote control can control the gas appliance after the pilot has been lit. It can turn the main burner on and regulate it from low through to high and back again. It can turn the main burner off leaving the pilot burning PART NUMBER 8455.
- 4.3 **THERMOSTATIC AND TIMER REMOTE CONTROL** This remote control can control the gas appliance after the pilot has been lit. In 'MANUAL MODE' it can be used to turn the main burner on and manually regulate it from low through to high and back again. It can also be used to turn the main burner leaving the pilot burning. In 'AUTO MODE' it will automatically regulate the room temperature to a pre-set temperature. In 'TIMER MODE' it will turn the fire on and off according to a pre-set programme and automatically regulate the room temperature during the two on periods. PART NUMBER 8456

5. CLEANING THE FIRE

WARNING: NEVER CLEAN THE STOVE WHILE IT'S HOT. THE STOVE STAYS HOT FOR A LONG TIME AFTER SHUTDOWN.

- 5.1 Make sure the fire and surrounds are cool before trying to clean.

5.2 REMOVING THE DOOR

For rear flue exit:

- Lift the top of the appliance off and put to one side.

For top flue exit:

- Lift and support the top to give clearance, Diagram 3

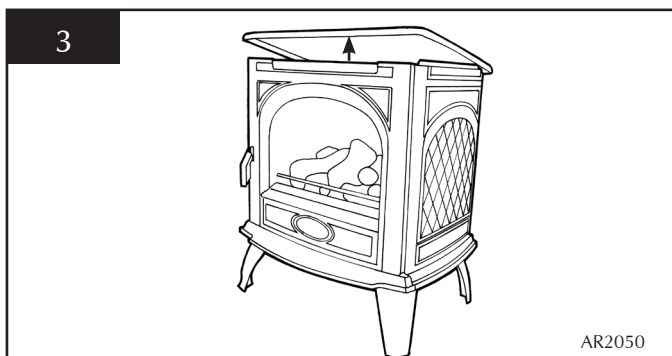

- Lift the front upwards until it is clear of the slots
- Pull towards you away from the stove, Diagram 4

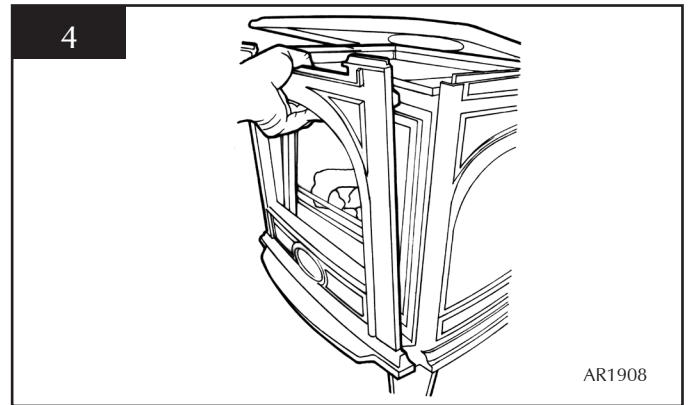

- Remove the glass frame by undoing the frame fixing screws and lifting clear, Diagram 5

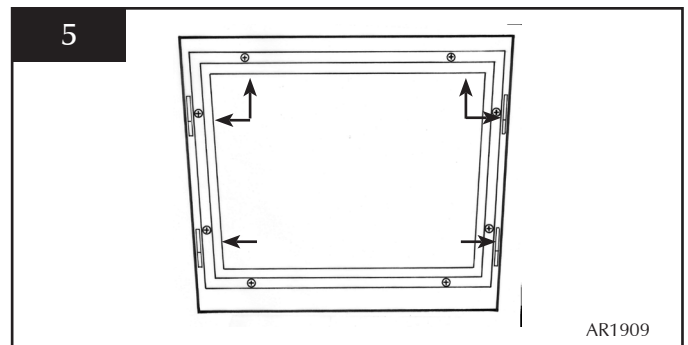

- 5.3 Carefully remove the ceramic fuel bed components and set aside, ensuring you protect the floor coverings and follow the Advice given at the start of Section 6.
- 5.4 The coals do not require cleaning. Do not use a vacuum cleaner or brush to clean the coals, any large pieces of debris can be removed by hand.
- 5.5 Ensure any debris is removed from the burner ports.
- 5.6 Replace the ceramics by referring to Section 6.
- 5.7 Use a damp cloth to clean the outer casing of the appliance.

USER INSTRUCTIONS

6. FUEL BED ARRANGEMENT

ADVICE ON HANDLING AND DISPOSAL OF FIRE CERAMICS

The fuel effect and side panels in this appliance are made from Refractory Ceramic Fibre (RCF), a material which is commonly used for this application.

Protective clothing is not required when handling these articles, but we recommend you follow normal hygiene rules of not smoking, eating or drinking in the work area and always wash your hands before eating or drinking.

To ensure that the release of RCF fibres are kept to a minimum, during installation and servicing a HEPA filtered vacuum is recommended to remove any dust accumulated in and around the appliance before and after working on it. When servicing the appliance it is recommended that the replaced items are not broken up, but are sealed within heavy duty polythene bags and labelled as RCF waste.

RCF waste is classed as stable, non-reactive hazardous waste and may be disposed of at a licensed landfill site.

Excessive exposure to these materials may cause temporary irritation to eyes, skin and respiratory tract; wash hands thoroughly after handling the material.

- Put the flame baffle onto the burner and push against the rear tray lip, Diagram 6

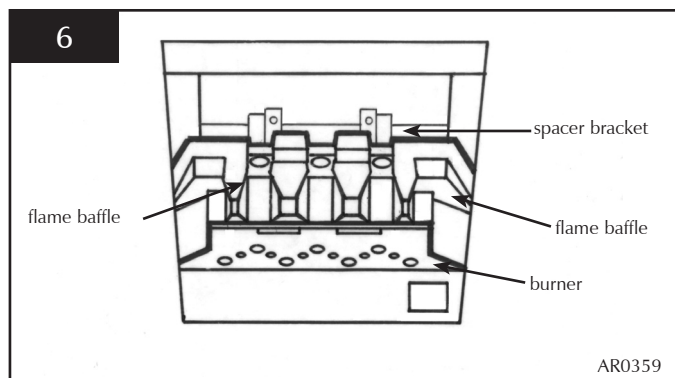

- Place the rear panel against the spacer brackets and slide it down to sit on the ledge of the flame baffle Diagram 7

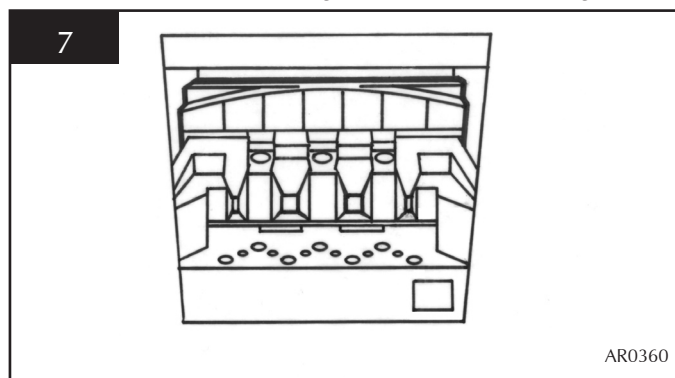

- Place the front coal between the heat shield and the flame baffle so that its ends sit flat against the burner skin, Diagram 8

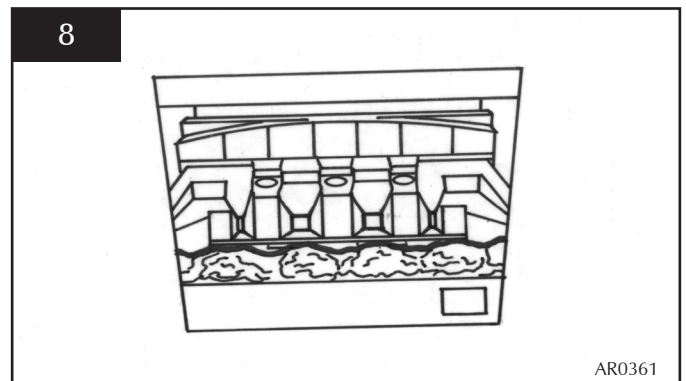

- Put five of the round coals on the front between the fingers of the flame baffle.
- Put two rectangular coals behind the first row and at either side to touch the reflector panels, Diagram 9

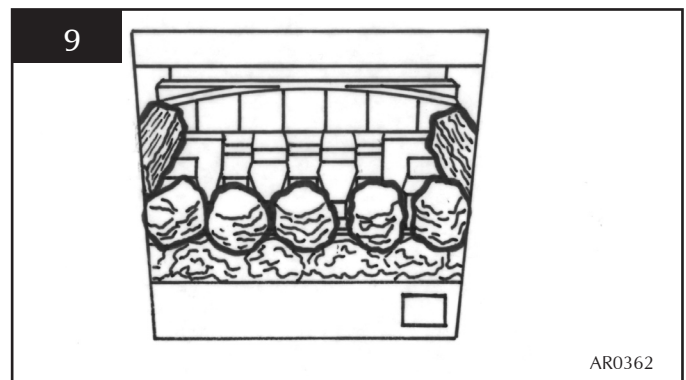

- Place four more round coals behind the first row so they sit on the fingers, the two at each side touch the rectangular coals, Diagram 10

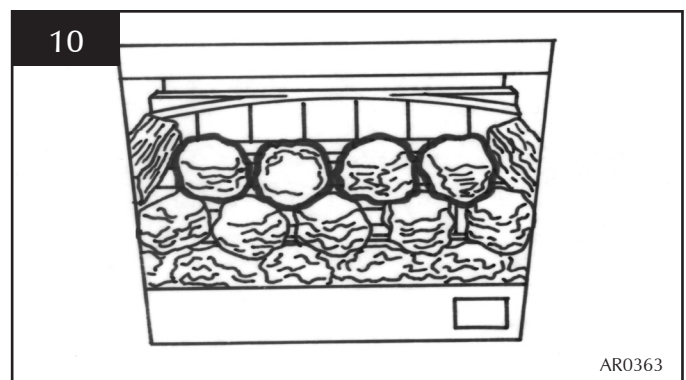

- Put the last three round coals behind the centre row and touching the back panel, Diagram 11

USER INSTRUCTIONS

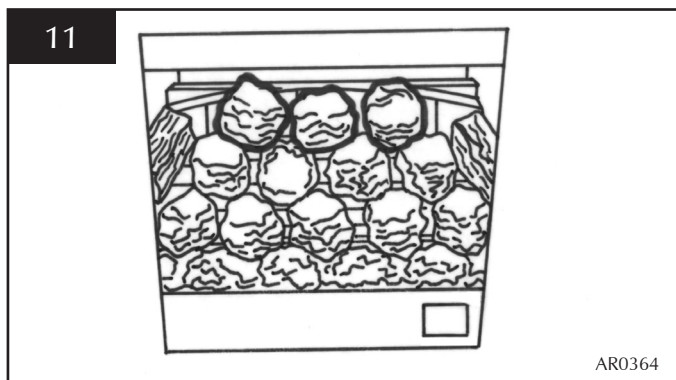

7. REPLACING THE DOOR

- 7.1 Ensure the rope seal fitted to the rear of the glass frame is intact.
- Use a ceramic glass product generally sold for cleaning ceramic hobs to clean the glass front
 - Refit glass frame and tighten screws evenly, Diagram 12

NEVER OPERATE THE STOVE WHEN THE GLASS FRAME IS REMOVED, OR THE GLASS IS BROKEN.

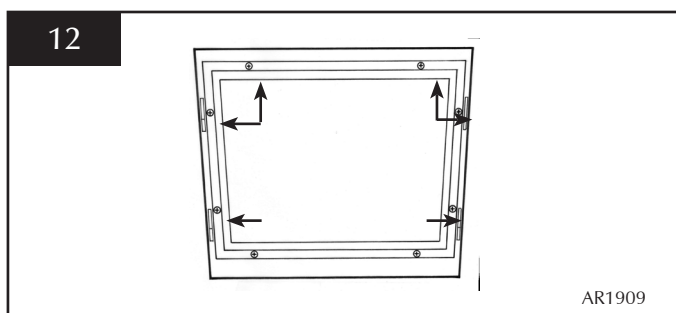

With the top still supported or removed:

- Refit front by locating in grooves and lowering into place, Diagram 13

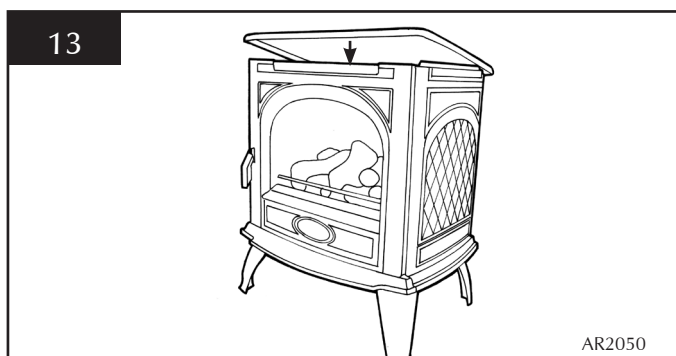

- Now replace top, Diagram 14

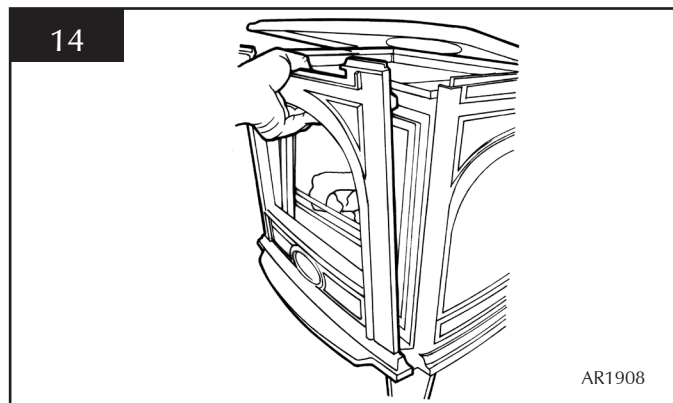

8. FLUE SURE SYSTEM

- 8.1 The stove is fitted with the Dovre Flue Sure System, which will act to cut off the gas supply to the burners in the event of incorrect operation of the flue. If the system acts to cut off the gas supply, this indicates that there is insufficient flue pull. If this occurs a minimum of 10 minutes should be allowed before trying to relight. Continued operation of this safety device means there may be a serious problem with the flue system. A qualified gas engineer should inspect this. **Do not use the stove until an engineer says it is safe to do so.**

9. THE FLAME FAILURE DEVICE

- 9.1 This is a safety feature incorporated in Dovre stoves which automatically switches off the gas supply if the pilot light goes out and fails to heat the thermocouple.

10. 'RUNNING IN'

- 10.1 The surface coating on your Dovre stove will 'burn off' during the first 24 hours of operation on high, producing a harmless and temporary odour. If the odour persists ask your retail for advice.

11. SERVICING

- 11.1 A qualified gas engineer must service the stove every 12 months. In all correspondence, always quote the appliance type and the serial number that may be found on the data badge on the appliance.

USER INSTRUCTIONS

12. VENTILATION

- 12.1 Any purpose provided ventilation should be checked periodically to ensure that it is free from obstruction.

13. INSTALLATION DETAILS

- 13.1 To assist in any future correspondence, your installer should have completed this commissioning sheet, this records the essential installation details of this appliance. In all correspondence always quote the model No. and serial No.

14. HOT SURFACES

- 14.1 Parts of this appliance become hot during normal use. It is therefore recommended that a suitable fire guard be used for protection of young children and the infirm. Indeed, all parts of the appliance should be treated as a 'working surface' except for the control touch pad area and access panel.

INSTALLATION INSTRUCTIONS

TECHNICAL SPECIFICATION

Covering the following models

DV-280CFNG
DV-280CFLPG

Model CAT.	Gas	Gas Type	Working Pressure	NOX Class	Aeration	Injector	Gas Rate m ³ /h	Input kW (Gross)		Country
								High	Low	
DV-280CFNG	I _{2H} G20	Natural Gas	20 mbar	5	1 x 7.5mm	260	0.435 Gross	4.6 Gross	2.5 Gross	GB, IE
DV-280CFLPG	I _{3P}	LPG Propane G31	37 mbar	5	1 x 13.5mm	110	0.170	4.4 Gross	2.3 Gross	GB, IE
Efficiency Class II Flue Outlet Size 127mm (5") ø Gas Inlet Connection Size 8mm ø										
Minimum flue specification			T260 / N2 / O / D / 1							
Maximum flue temperature			180°C							

Packing Checklist

Qty	Description
1	Stove
1	Flue infill plate
1	Front coal
1	Flame baffle
1	Coal set
1	Rear ceramic
1	Fixing kit containing
1	Instruction manual

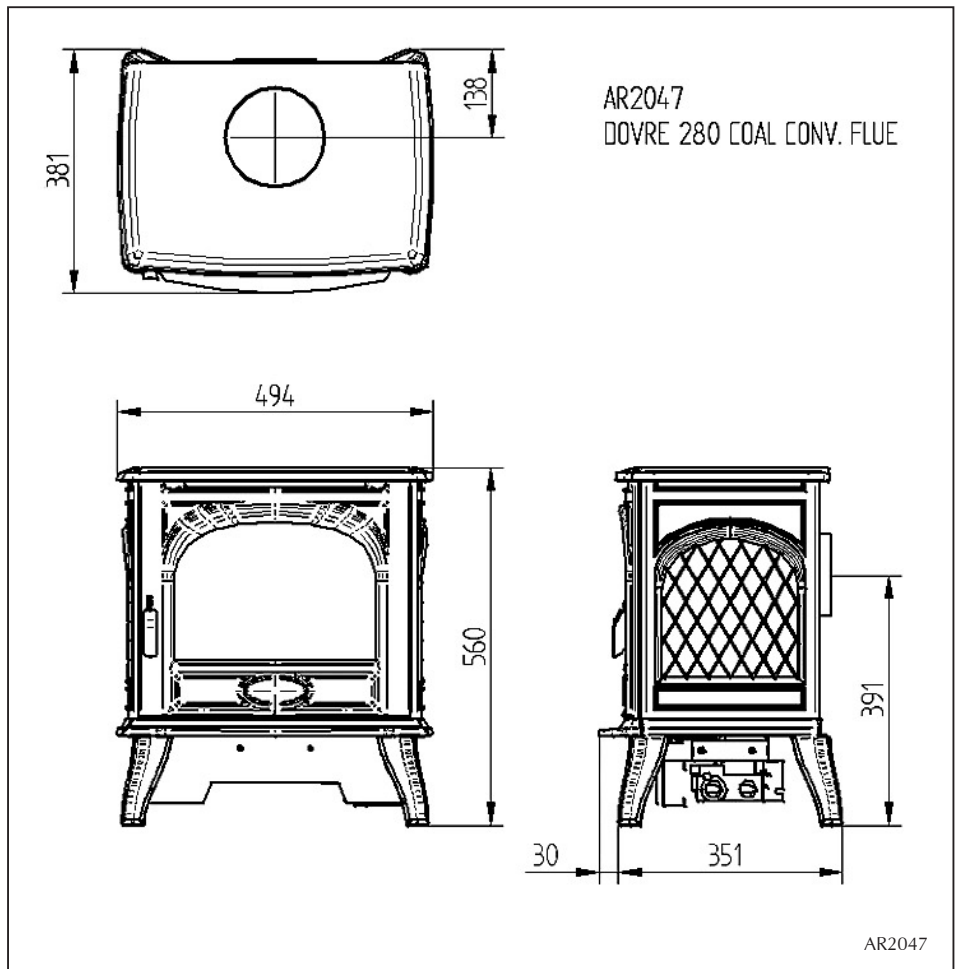

INSTALLATION INSTRUCTIONS

SITE REQUIREMENTS

1. FLUE AND CHIMNEY REQUIREMENTS

- 1.1 The chimney or flue system must comply with the rules in force, and must be a minimum of 127mm in diameter. (5").
- 1.2 The minimum flue height for the appliance must be 3 metres (10ft). Any horizontal flue run from the rear outlet must not exceed 100mm from the back of the appliance.
- 1.3 The chimney or flue must be free from any obstruction. Any damper plates must be removed or secured in the fully open position, and no restrictor plates fitted.
- 1.4 The chimney must be swept prior to the installation, but it need not be swept if it can be seen the chimney is clean and unobstructed throughout its entire length.
- 1.5 If it is intended to fit the stove into a existing brick built chimney, a 5" (127mm) liner must be used. Larger lined flues may work, but in some instances could cause cold start flue problems resulting in nuisance shutdown. Lined flues above 7" (175mm) are not recommended.
- 1.6 Due to recent changes to European chimney standards, new flues and chimneys are described by their temperature, pressure and resistance to corrosion, condensation and fire. To assist in identifying the correct flue system, the minimum flue specification is shown in the *Technical Specification* on page 9 of this book. Existing chimneys are not covered by this system.

2. VENTILATION

- 2.1 Consult the rules in force.
Note: This appliance does not normally require any additional ventilation when installed in G.B.

3. INSTALLATION OF THE GAS SUPPLY

- 3.1 Before installation, ensure that the local distribution conditions (identification of the type of gas and pressure) and the adjustment of the appliance are compatible.
- 3.2 Ensure the gas supply is capable of delivering the required amount of gas, and is in accordance with the rules in force.
- 3.3 Soft copper tubing and soft soldered joints can be used but must not be closer than 50mm to the base of the tray.
- 3.4 A means of isolating the gas supply to the appliance must be provided independent of any appliance control.
- 3.5 All supply gas pipes must be purged of any debris that may have entered, prior to connection to the appliance.

4. APPLIANCE LOCATION

- 4.1 This appliance must stand on a non-combustible hearth that is at least 12mm thick, and project a minimum of 50mm from the base of the stove in all directions, Diagram 1.

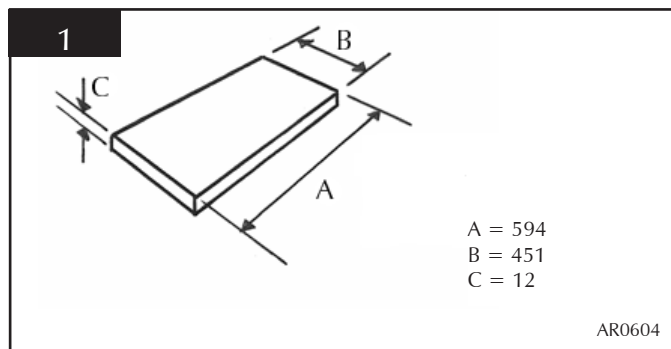

- 4.2 This appliance must not be installed in a room that contains a bath or shower.
- 4.3 The stove is not suitable for installation against a combustible wall; all combustible materials must be removed from the area behind the stove.
- 4.4 Ensure you comply to all minimum clearances to combustible materials. See Diagram 2 & 2A.

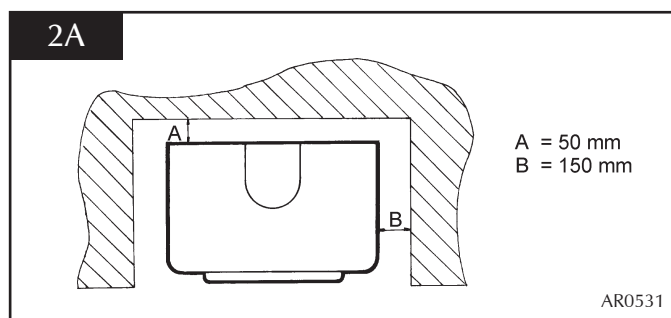
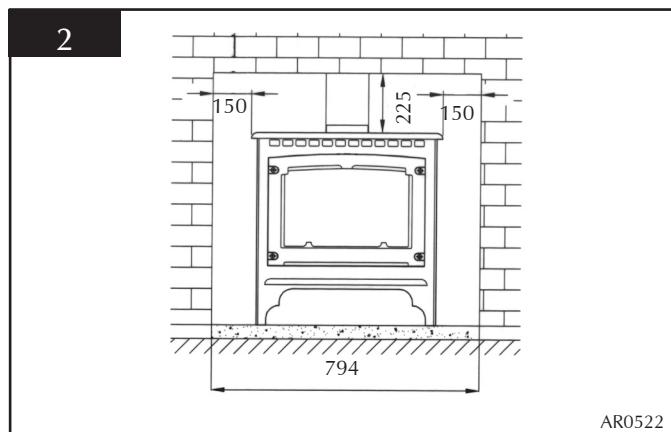

In a non-combustible recess be careful to allow enough clearance at the sides and rear of the stove to perform spillage tests and reach the controls.

INSTALLATION INSTRUCTIONS

INSTALLATION

IMPORTANT: ENSURE THAT THE APPLIANCE IS CORRECTLY ADJUSTED FOR THE GAS TYPE AND CATEGORY APPLICABLE IN THE COUNTRY OF USE. REFER TO DATA BADGE AND TECHNICAL SPECIFICATIONS AT THE FRONT OF THIS BOOKLET. FOR DETAILS OF CHANGING BETWEEN GAS TYPES REFER TO *SERVICING SECTION, REPLACING PARTS*

1. CONTROL UPGRADE

- 1.1 This stove is fitted with a control valve that can be easily upgraded to battery powered remote control. There are two versions of this control which can be obtained through your local Stovax stockist.
- 1.2 This upgrade can be fitted before or after installation but if side clearances are limited then it will be easier to upgrade the stove before installation. Full instructions are included with the kit.
- 1.3 **STANDARD REMOTE CONTROL** This remote control can control the gas appliance after the pilot has been lit. It can turn the main burner on and regulate it from low through to high and back again. It can turn the main burner off leaving the pilot burning. Gazco PART NUMBER 8455.
- 1.4 **THERMOSTATIC AND TIMER REMOTE CONTROL** This remote control can control the gas appliance after the pilot has been lit. In 'MANUAL MODE' it can be used to turn the main burner on and manually regulate it from low through to high and back again. It can also be used to turn the main burner off leaving the pilot burning. In 'AUTO MODE' it will automatically regulate the room temperature. In 'TIMER MODE' it will turn the fire on and off according to a pre-set programme and automatically regulate the room temperature during two on periods. Gazco PART NUMBER 8456

2. SAFETY PRECAUTIONS

- 2.1 This appliance must be installed in accordance with the rules in force, and used only in a sufficiently ventilated space. Please read these instructions before installation and use of this appliance.
- 2.2 All the instructions must be left intact with the user.
- 2.3 In your own interest, and those of safety, this appliance must be installed by a competent person in accordance with local and national codes of practice. Failure to install the appliance correctly could lead to prosecution.
- 2.4 This appliance is intended for use on a governed gas installation and set to the required pressure.
- 2.5 Keep all plastic bags away from young children.
- 2.6 Do not place any object on or near to the stove. Allow adequate clearance above the stove. See diagram 2 page 9.
- 2.7 The stove is fitted with the **Stovax Flue Sure System**, which cuts off the gas supply to the stove in the event of incorrect flue operation. If the system shuts off the gas supply, this

indicates there is insufficient flue pull. If this happens, a minimum of 10 minutes must be allowed before trying to relight. If this safety device is continually shuts off the gas it can suggest a serious problem:

- Contact Stovax
- 2.8 Do not alter or tamper with the Flue Sure System. Use only genuine Stovax replacement parts when servicing the system - refer to the *Servicing Section, Replacing Parts*.

3. INSTALLATION OF THE STOVE

- 3.1 Open the carton
 - 3.1.1 Remove the accessory carton and stove unit
 - 3.1.2 Decide whether to use top or rear flue exit:
 - The stove is factory built for rear flue exit but it can be changed to top exit by swapping the flue spigot and blanking plate located on the stove.
- 3.2
 - Position the stove ensuring all appropriate clearances are observed
- 3.3 Having run the gas supply to the stove:
 - **PURGE THE SUPPLY PIPE**
This is essential to expel any debris that can block the gas controls.
 - Connect the gas supply to the 8mm-compression elbow at the right-hand rear corner of the stove
There is a cutout in the right-hand rear leg to enable a straight connection to the rear of the stove, Diagram 3. A gas soundness check must be completed up to the gas inlet connection.

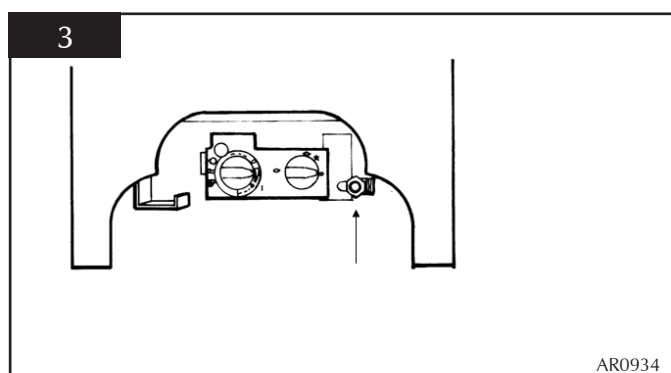

- 3.4
 - Check the pull of the flue system by applying a lighted smoke pellet to the flue system opening
If there is a definite flow into the chimney, proceed with the installation. If not, warm the chimney for a few minutes.

INSTALLATION INSTRUCTIONS

INSTALLATION

IF THERE IS STILL NO DEFINITE FLOW, THE FLUE MAY REQUIRE ATTENTION - SEEK EXPERT ADVICE

- 3.5 The flue system can now be connected to the stove:
- Ensure all joints are sealed with a suitable fire resistant sealant.

We recommend you use self-tapping screws at the flue spigot joint.

- 3.6
- Connect a suitable pressure gauge to the test point located on the inlet fitting,
 - Turn the gas supply on
 - Light the appliance and check all gas joints for gas soundness
 - Turn the appliance to a maximum and check that the supply pressure is as stated on the databadge.
 - Turn the gas off and replace the test point screw
 - Turn the gas on and check the test point for gas soundness.

3.7 REMOVING THE DOOR

For rear flue exit:

- Lift the top of the appliance off and put to one side.

For top flue exit:

- Lift and support the top to give clearance, Diagram 4

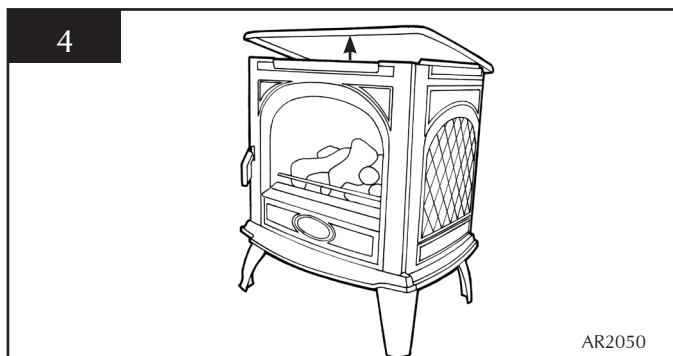

- Lift the front upwards until it is clear of the slots
- Pull towards you away from the stove, Diagram 5

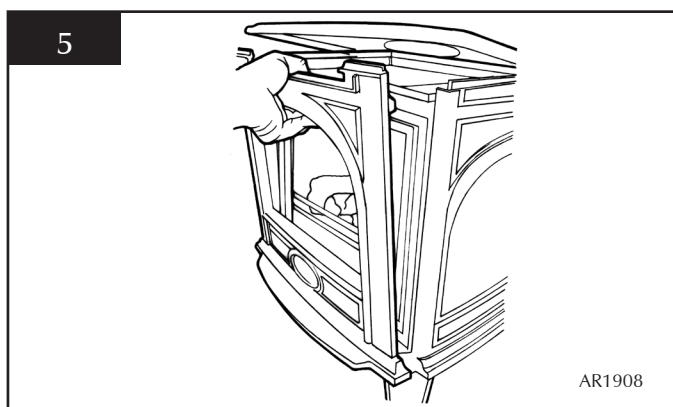

- Remove the glass frame by undoing the frame fixing screws and lifting clear, Diagram 6

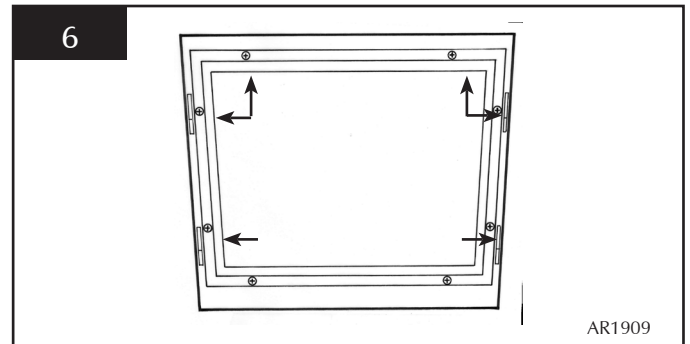

4. FUELBED ARRANGEMENT

ADVICE ON HANDLING AND DISPOSAL OF FIRE CERAMICS

The fuel effect and side panels in this appliance are made from Refractory Ceramic Fibre (RCF), a material which is commonly used for this application.

Protective clothing is not required when handling these articles, but we recommend you follow normal hygiene rules of not smoking, eating or drinking in the work area and always wash your hands before eating or drinking.

To ensure that the release of RCF fibres are kept to a minimum, during installation and servicing a HEPA filtered vacuum is recommended to remove any dust accumulated in and around the appliance before and after working on it. When servicing the appliance it is recommended that the replaced items are not broken up, but are sealed within heavy duty polythene bags and labelled as RCF waste.

RCF waste is classed as stable, non-reactive hazardous waste and may be disposed of at a licensed landfill site.

Excessive exposure to these materials may cause temporary irritation to eyes, skin and respiratory tract; wash hands thoroughly after handling the material.

- Put the flame baffle onto the burner and push against the rear tray lip, Diagram 7

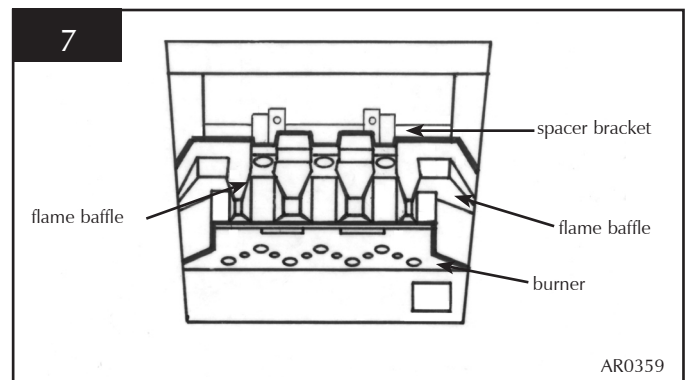

- Place the rear panel against the spacer brackets and slide it down to sit on the ledge of the flame baffle, Diagram 8

INSTALLATION INSTRUCTIONS

INSTALLATION

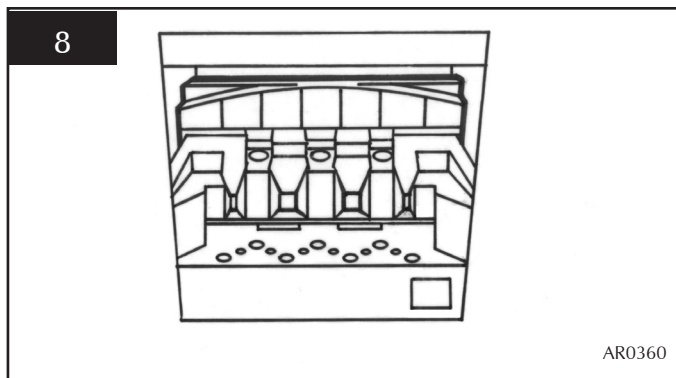

- Place the front coal between the heat shield and the flame baffle so that its ends sit flat against the burner skin Diagram 9

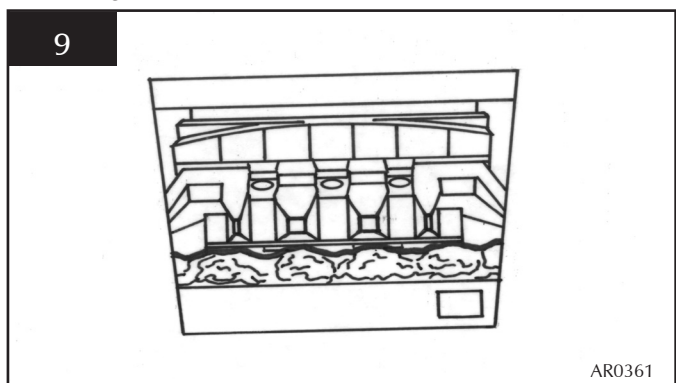

- Put five of the round coals on the front between the fingers of the flame baffle.
- Put two rectangular coals behind the first row and at either side to touch the reflector panels, Diagram 10

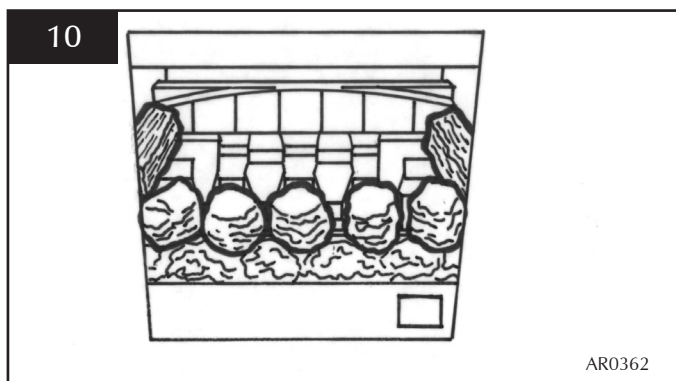

- Place four more round coals behind the first row so they sit on the fingers, the two at each side touch the rectangular coals, Diagram 11

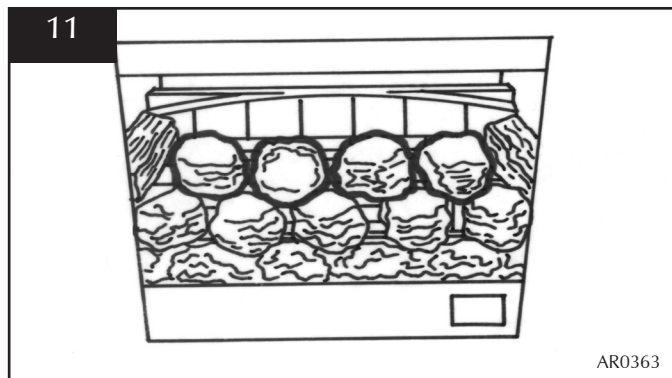

- Put the last three round coals behind the centre row and touching the back panel, Diagram 12

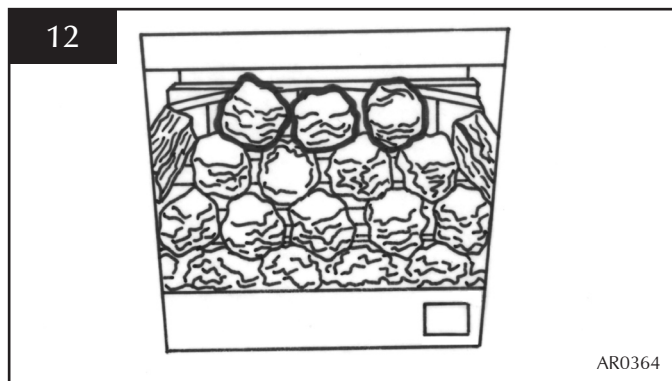

5. REPLACING THE DOOR

5.1 Ensure the rope seal fitted to the rear of the glass frame is intact.

- Refit glass frame and tighten screws evenly, Diagram 13

NEVER OPERATE THE STOVE WHEN THE GLASS FRAME IS REMOVED, OR THE GLASS IS BROKEN.

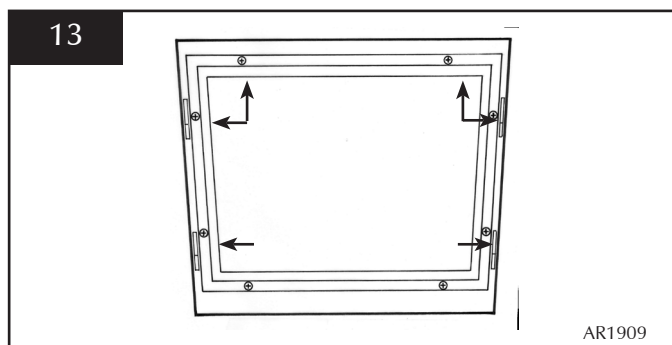

With the top still supported or removed:

- Refit front by locating in grooves and lowering into place, Diagram 14

INSTALLATION INSTRUCTIONS

INSTALLATION

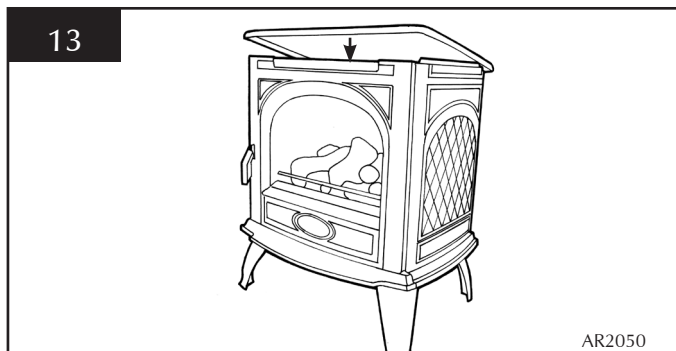

- Now replace top, Diagram 15

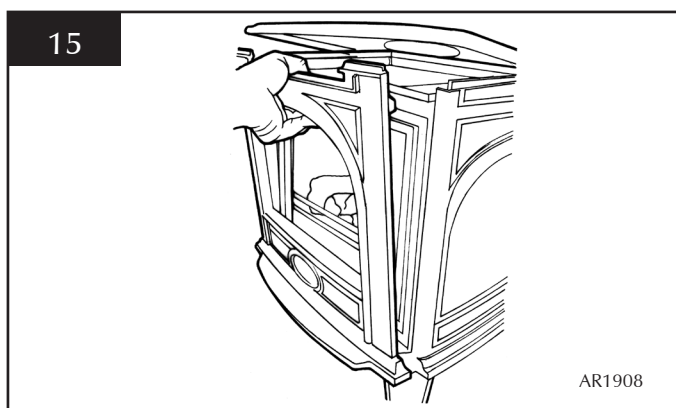

6. LIGHTING

6.1 Full instructions are given in the *User Section*.

INSTALLATION INSTRUCTIONS

COMMISSIONING

1. COMMISSIONING

- Close all openable doors and windows in the room
 - Ignite the stove and operate on maximum for 10 minutes
 - Position a lighted smoke match just inside the draught diverter opening
 - Check all smoke is drawn into the opening, Diagram 1
- If there is any doubt, run the stove for a further 10 minutes, and repeat the test.

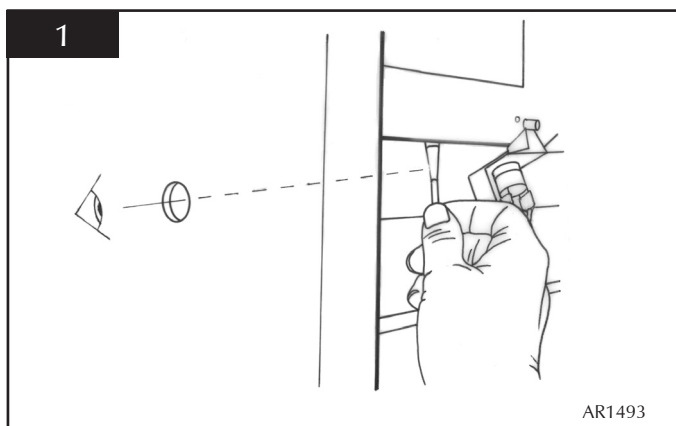

If there are any extractor fans in adjacent rooms, the test must be repeated with the fans running on maximum and interconnecting doors open.

IF SPILLAGE PERSISTS, DISCONNECT THE APPLIANCE AND SEEK EXPERT ADVICE.

For future reference record the installation details on the commissioning sheet at the start of these instructions.

SERVICING INSTRUCTIONS

SERVICING / FAULT FINDING CHARTS

1. SERVICING REQUIREMENTS

This appliance must be serviced at least once a year by a competent person.

All tests must be serviced by best practice as described by the current CORGI recommendations.

- 1.1 Before any test are undertaken on the appliance, conduct a gas soundness test for the property to ensure that there are no gas leaks prior to starting work.
- 1.2 Before any tests are undertaken on the appliance it is also recommended to fully check the operation of the appliance.
- 1.3 Special checks
 - 1.3.1 Clean any lint or fluff from the pilot - pay particular attention to the aeration hole in the side of the pilot
 - 1.3.2 Clean away any fluff or lint from under the burner
 - 1.3.3 Check that the spark gap on the pilot is correct, Diagram 1
- 1.4 Correct any faults found during the initial tests and then re-commission the appliance conducting the usual safety checks.
- 1.5 Advise the customer of any remedial action taken.

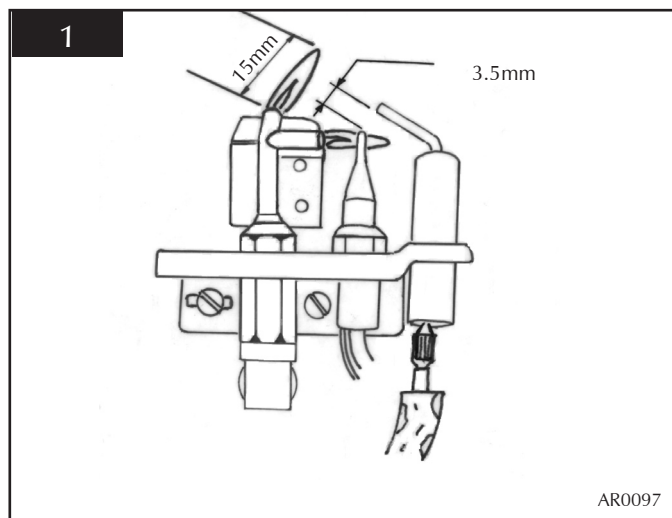

IGNITION FUNCTIONAL CHECK 1

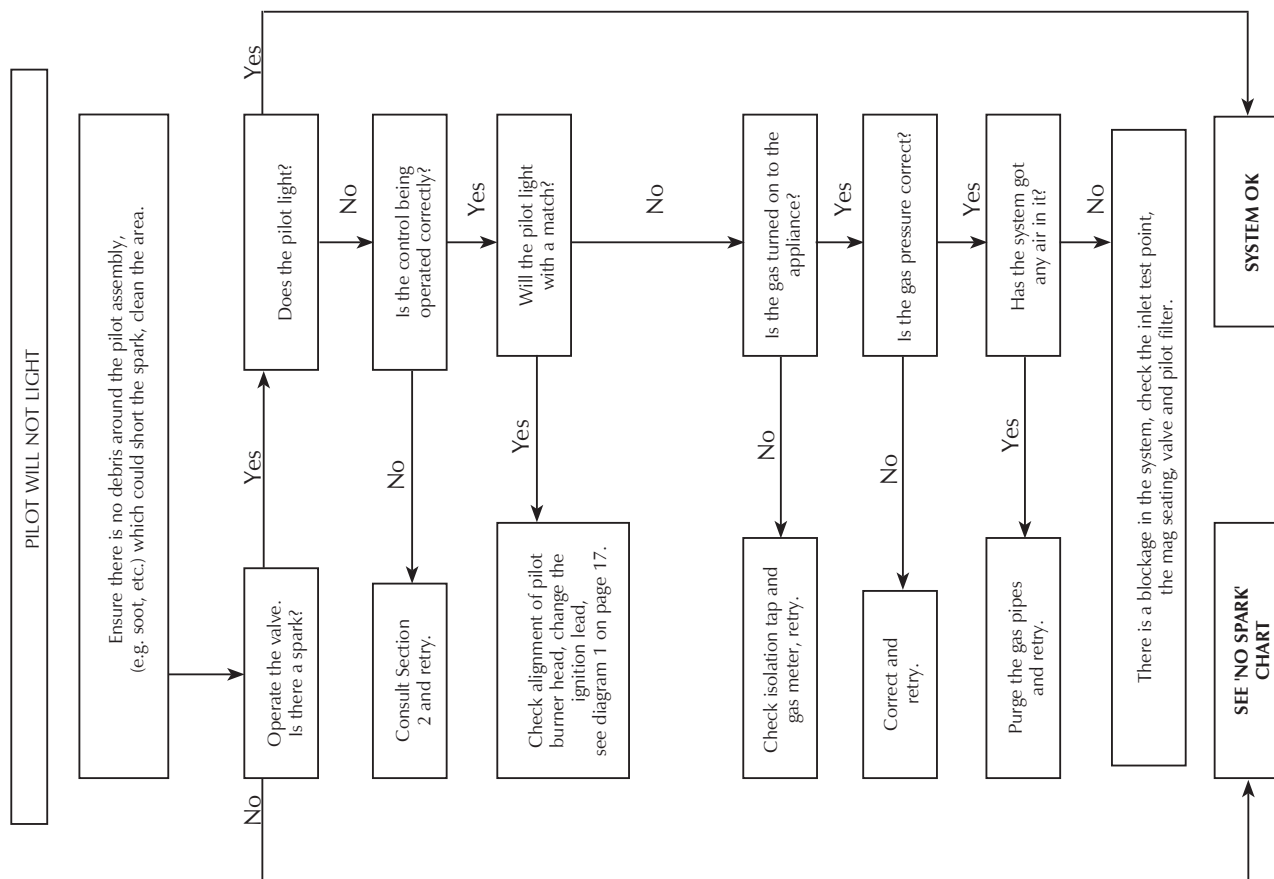

SERVICING INSTRUCTIONS

FAULT FINDING CHARTS

FLAME FAILURE FUNCTIONAL CHECK

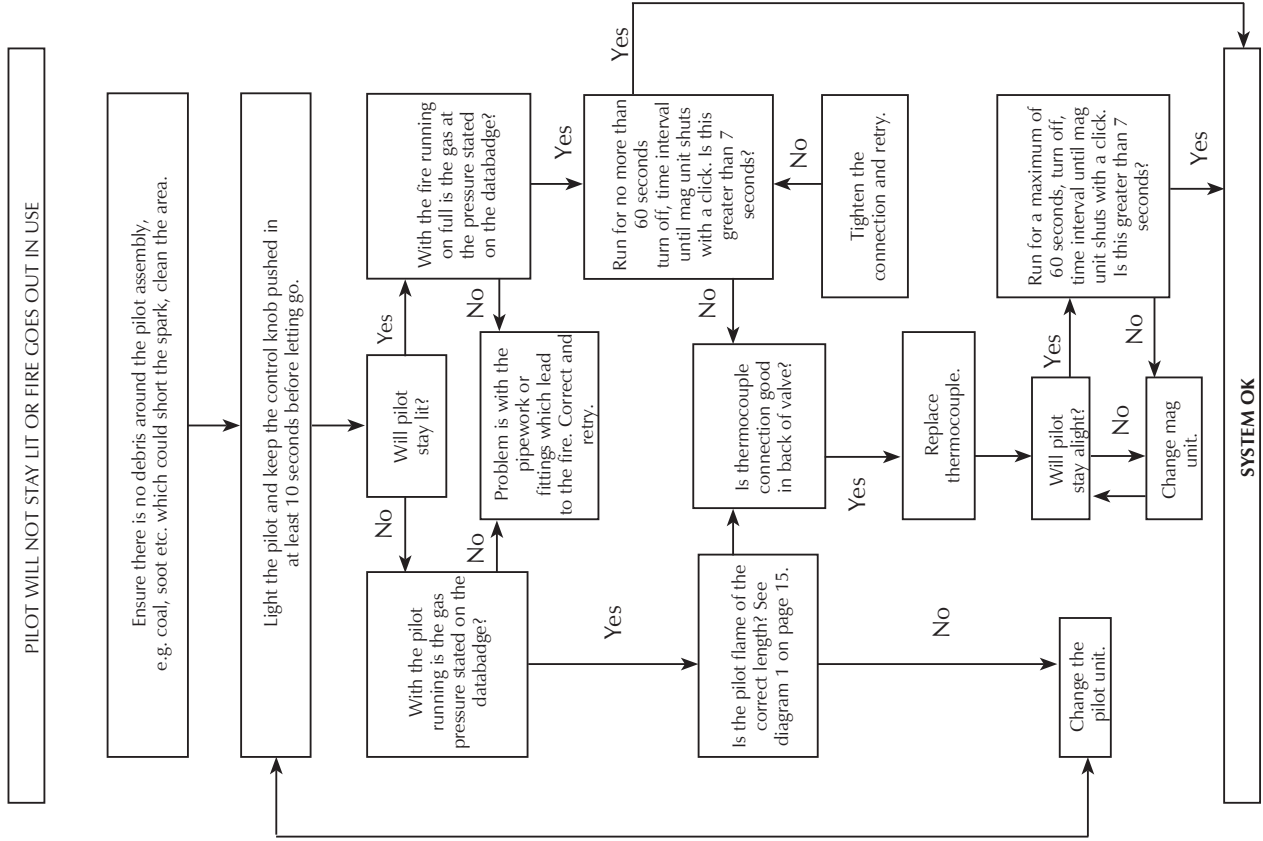

IGNITION FUNCTIONAL CHECK 2

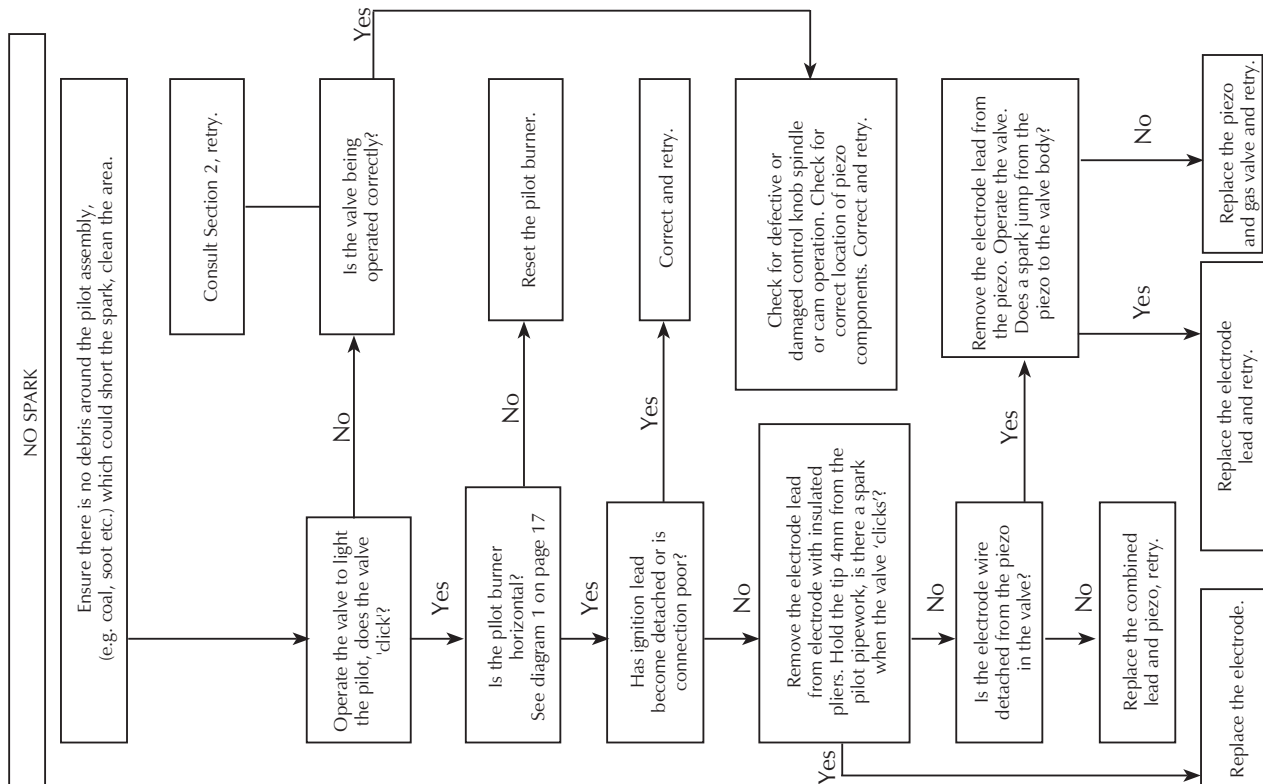

SERVICING INSTRUCTIONS

REPLACING PARTS

1. GENERAL

- 1.1 All principal components can be replaced without removing the stove from its installation, although it is essential that the gas supply to the appliance is turned off at the isolation device before proceeding further.

2. MAIN BURNER

2.1 **MAKE SURE THE APPLIANCE IS COLD BEFORE STARTING WORK ON IT!**

- Turn the gas supply off at the isolation device:
 - Use *Installation Section, Removing the Door*, in the this manual.
- Remove the door and place to one side
- Remove the ceramic fuel bed components.

For information on the handling and disposal of fire ceramics please refer to the *User Instructions, Fuelbed Arrangements*.

- Remove the cover plate from the bottom of the stove by undoing the mounting screws on the plate and place to one side, Diagram 1

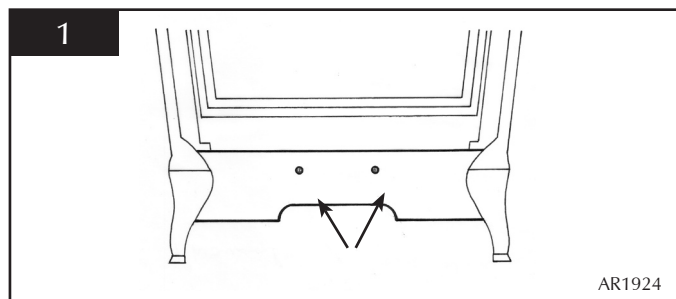

2.2 Referring to Diagram 2:

- Disconnect the thermocouple from the gas valve (A)
- Remove the ignition lead from the electrode (B)
- Cut the cable tie if required
- Undo the compression nut (C) from the pilot unit and undo the compression nut on the injector (D).

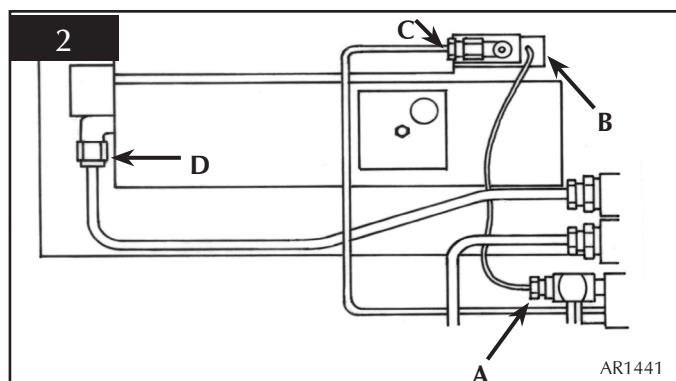

- 2.4 Remove the two screws at the back of the firebox and lift the burner unit clear Diagram 3

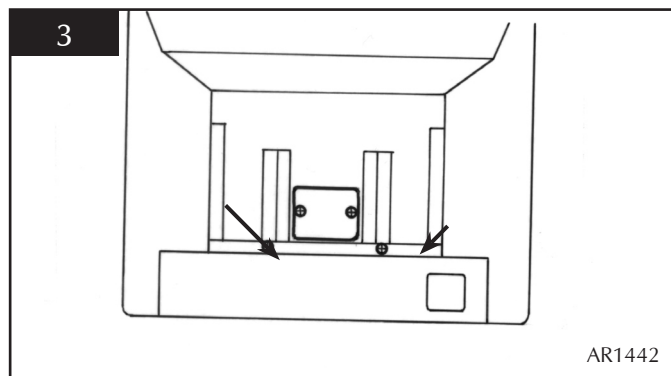

3. PILOT UNIT

- 3.1
- Follow the procedure for removing the main burner
- When the burner is out:
- Remove the aeration cover by undoing the two screws, Diagram 4

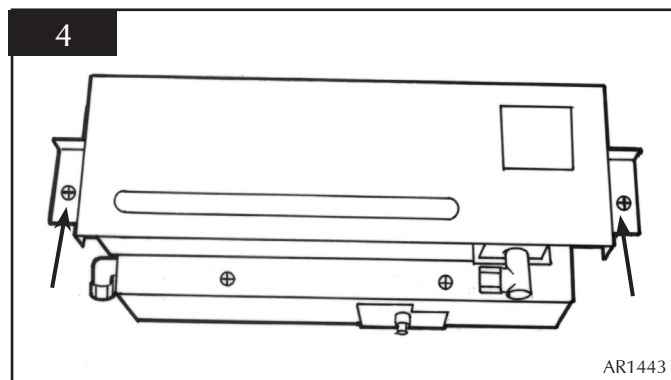

- Remove the lint arrester, by folding the tabs back Diagram 5

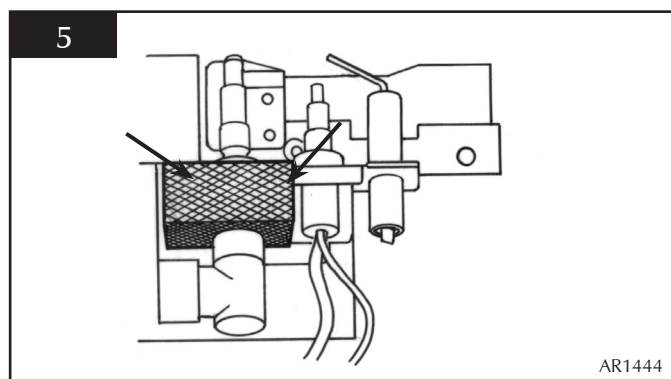

SERVICING INSTRUCTIONS

REPLACING PARTS

The pilot unit can now be removed by undoing the two screws, Diagram 6

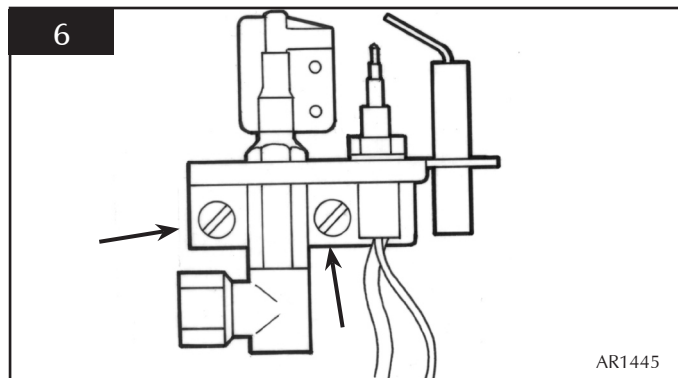

- 3.2
- Reassemble in reverse order
 - Do not overtighten.

NOTE: TAKE CARE NOT TO DISCONNECT THE SENSOR WIRES OF THE FLUE SURE SYSTEM ON REPLACING THE THERMOCOUPLE

4. IGNITION LEAD AND PIEZO

- 4.1
- Follow the above *Pilot Unit* instruction to access the back of the pilot assembly
 - Disconnect the ignition lead from the electrode
 - Remove the front cover from the control valve, Diagram 7 and 8
 - Disconnect the other end of the ignition lead from the valve body noting the route of the ignition lead

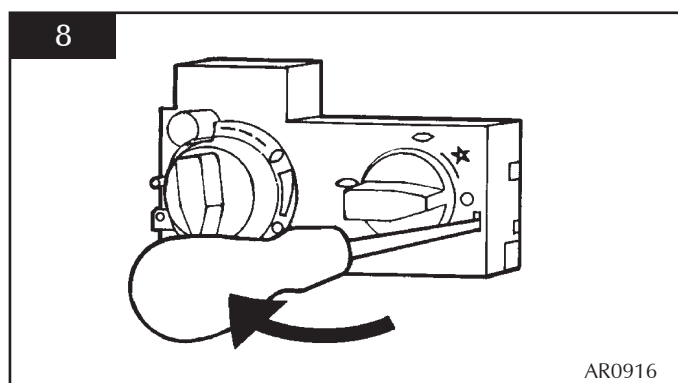
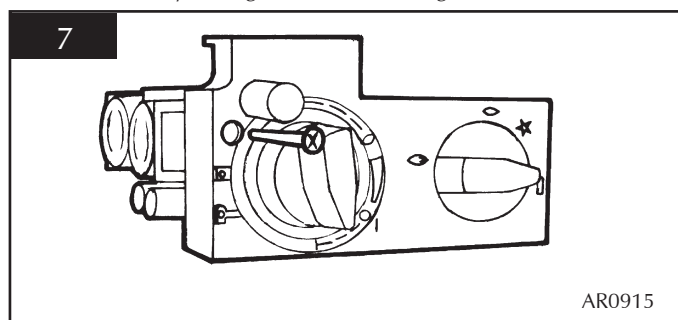

- Replace with a new ignition lead following the same route as the old one

Replace the valve cover and the pilot assembly

- 4.2
- Check operation of the new ignition lead.

5. PIEZO

- 5.1
- The piezo assembly used on this appliance is not serviceable and is unlikely to fail.

6. GAS VALVE

- 6.1
- Turn the gas supply off at the isolation device, referring to Diagram 9
 - Disconnect the 2 x 8mm and 1 x 4mm gas pipe fittings at the back of the gas valve (A)
 - Disconnect the thermocouple, (B)

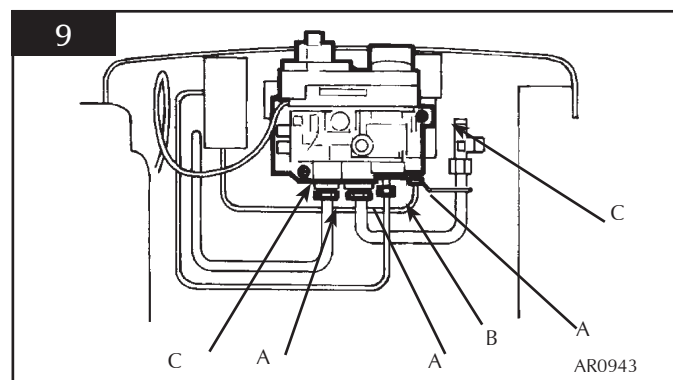

- Remove the front cover from the control valve, Diagram 10 and 11

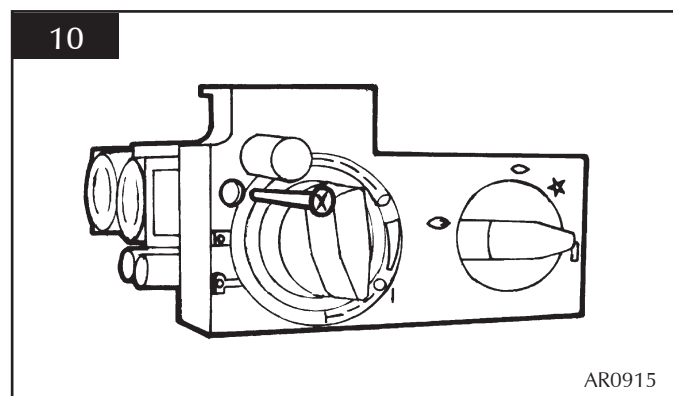

SERVICING INSTRUCTIONS

REPLACING PARTS

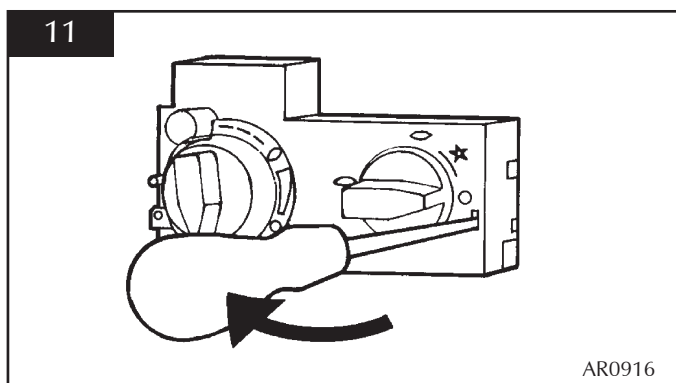

- 6.2 There is a small cylindrical metal spacer inside the cover, this must be kept and replaced on the fixing screw during re-assembly
- Disconnect the ignition lead from the gas valve
 - Undo the two bolts securing the gas valve to the appliance and remove the valve, Diagram 9 (C)
 - Replace in reverse order
 - Check all joints for gas leaks
 - Check operation of the thermocouple and ignition lead.

7. MAGNETIC SAFETY VALVE

- 7.1
- Turn the gas supply off at the isolation device, referring to Diagram 12
 - Undo the thermocouple connection from the back of the gas valve (A)
 - Pull the sensor leads clear and remove the interrupter block (B)
 - Undo the magnetic valve-retaining nut from the back of the control valve (C)
 - Gently tap out the magnetic valve and replace with a new unit
 - Replace the retaining nut and tighten, Diagram 12.

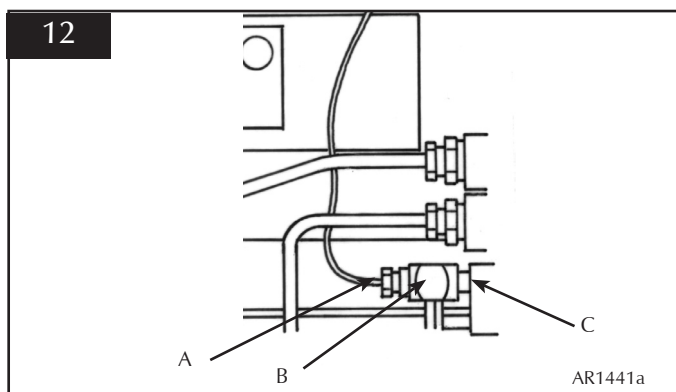

- 7.2
- Reassemble the interrupter block and leads
 - Secure the thermocouple connection in the rear of the gas control. (Do not overtighten)
 - Turn the gas supply on and
 - Check the entire pipework and valve joints for any leaks

8. MAIN INJECTOR

- 8.1
- Turn the gas supply off at the isolation device
 - Ensure the appliance is cold before commencing work on it

Referring to Diagram 13:

- Undo the compression nut from the injector (A)
- Loosen the compression nut (B) in the gas valve body. The pipe can now be positioned out of the way.
- Screw the injector (C) out of the burner unit.

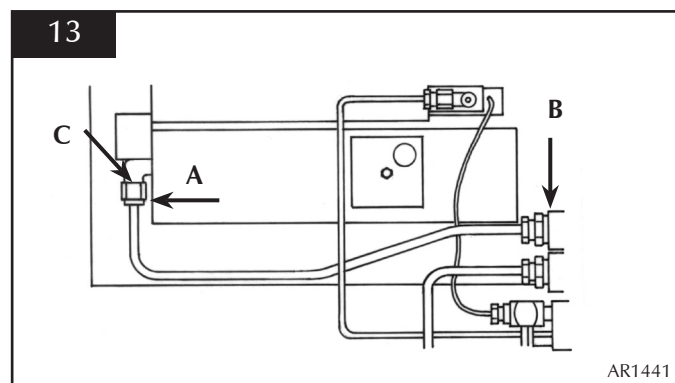

- 8.2
- Reassemble in reverse order. The injector must **NOT** be tightened into the burner but be allowed to float to enable it to line up with the pipe.
 - Turn on the gas supply and check for leaks

SERVICING INSTRUCTIONS

REPLACING PARTS

9. FLUE SURE SYSTEM

- 9.1
- Open the door and remove the ceramics, placing them carefully to one side.
 - Undo the two screws in the back of the firebox and carefully withdraw the bracket, Diagram 14 and 15

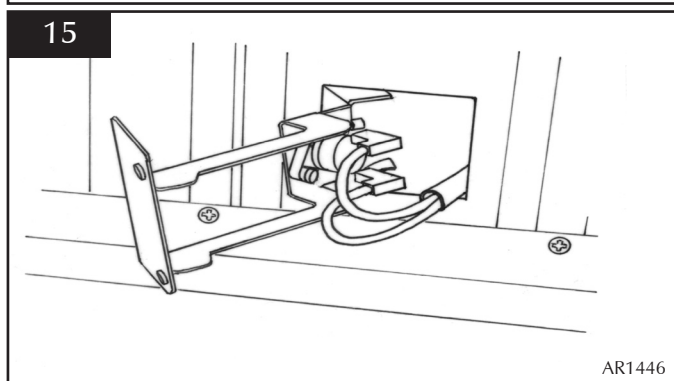
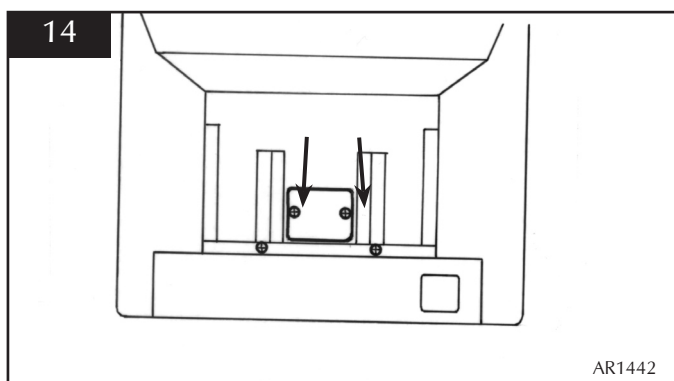

- 9.2
- Disconnect the two sensor wires
 - Undo the two tapite screws
 - Remove the sensor and the two plastic spacers, Diagram 16

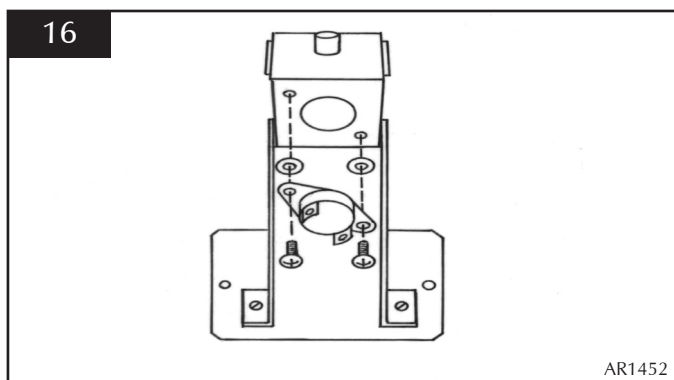

- 9.3
- Refit the new sensor ensuring the plastic spacers are

located between the bracket and the sensor

- Refit the leads
- 9.4
- Feed the cable back through the hole as you replace the bracket.

When the bracket is located correctly it sits flush with the back panel without force. If not positioned correctly the bracket sits at an angle, Diagram 17

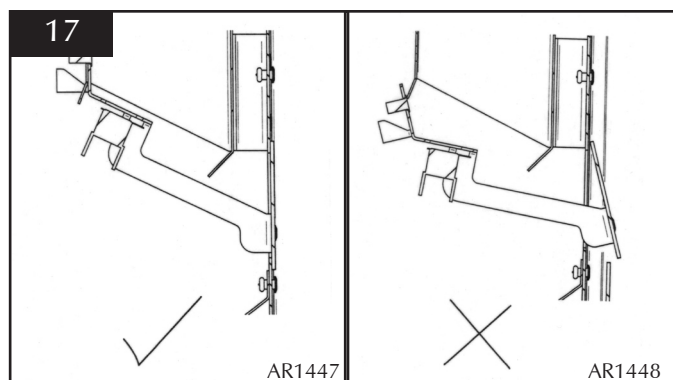

10. PRIMARY AERATION PLATE

- 10.1 Turn to Section 3.8 *Removing the Door*, in the *Installation Section* of this manual.

- Remove the door and place to one side
- Remove the cover plate from the bottom of the stove by undoing the screws, Diagram 18

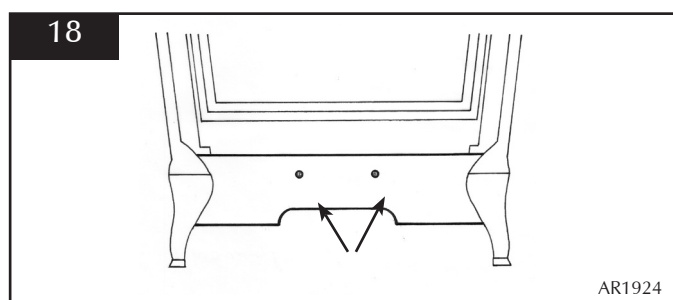

- Undo the M5 nyloc nut from the bottom of the burner unit and remove the aeration plate, Diagram 19

SERVICING INSTRUCTIONS

REPLACING PARTS

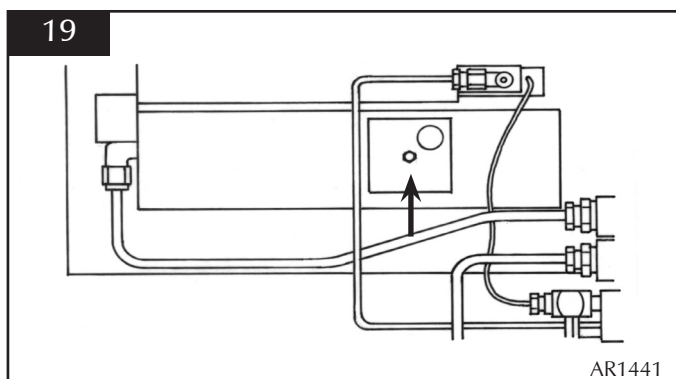

- Reassemble in reverse order with the correct aeration plate.

11. CHANGING BETWEEN GAS TYPES

In order to change between gas types, it will be necessary to change the following items.

- Pilot Injector
- Control Valve**
- Main Injector
- Aeration Plate
- Data badge

The relevant parts can be ordered from Stovax, always quote the appliance type and serial number when ordering spare parts.

**** NOTE: THE CONTROL VALVE IS FACTORY PRESET FOR CORRECT GAS TYPE AND MODEL, A NEW UNIT WILL NEED TO BE ORDERED WHEN CHANGING BETWEEN GAS TYPES.**

12. CONTROL UPGARDE

See *Installation Instructions, Section 1.*

13. SHORT SPARES LIST

	NG	LPG
COMPONENT	G20	G31
	20mb	37mb
MAIN INJECTOR	IN0001	IN0054
AERATION PLATE	ME4066	ME4954
PILOT INJECTOR	PI0036	PI0037
BURNER ASSEMBLY	B0214	PB0214
THERMOCOUPLE	PI0010	
MAGNETIC UNIT	GC0092	
ELECTRODE	PI0053	
GAS VALVE	GC0088K**	
IGNITION LEAD	GC0090	
FRONT COAL	CE0122	
FLAME BAFFLE	CE0118	
REAR PANEL	GC0135	
COAL SET	GC0127	
TTB SENSOR	EL0001	
SENSOR LEAD	EL0064	
INTERRUPTER	GC0029	
STANDARD UPGRADE KIT	8455	
THERMO UPGRADE KIT	8456	
** Note :- The control valve is factory preset for correct gas type and model.		

SERVICE RECORDS

1ST SERVICE

Date of Service:
Next Service due:
Signed:
Dealer's Stamp/CORGI Registration Number

2ND SERVICE

Date of Service:
Next Service due:
Signed:
Dealer's Stamp/CORGI Registration Number

3RD SERVICE

Date of Service:
Next Service due:
Signed:
Dealer's Stamp/CORGI Registration Number

4TH SERVICE

Date of Service:
Next Service due:
Signed:
Dealer's Stamp/CORGI Registration Number

5TH SERVICE

Date of Service:
Next Service due:
Signed:
Dealer's Stamp/CORGI Registration Number

6TH SERVICE

Date of Service:
Next Service due:
Signed:
Dealer's Stamp/CORGI Registration Number

7TH SERVICE

Date of Service:
Next Service due:
Signed:
Dealer's Stamp/CORGI Registration Number

8TH SERVICE

Date of Service:
Next Service due:
Signed:
Dealer's Stamp/CORGI Registration Number

9TH SERVICE

Date of Service:
Next Service due:
Signed:
Dealer's Stamp/CORGI Registration Number

10TH SERVICE

Date of Service:
Next Service due:
Signed:
Dealer's Stamp/CORGI Registration Number



United Kingdom and Eire distributors for Dovre:

STOVAX

Stovax Limited, Falcon Road, Sowton Industrial Estate, Exeter, Devon, England, EX2 7LF.

Telephone: **(01392) 474011** Fax: **(01392) 219932**

E-mail: dovre@stovax.com Internet: www.dovre.co.uk